

Rack & Panel

SLE-SME-SRE Series

Sub Miniature / High Density Rectangular / .025" Dia. / 3 Amps .030" Dia. / 5 Amps / .040" Dia. / 7.5 Amps



SLE
.025 Diameter Contacts —
3 Amps.

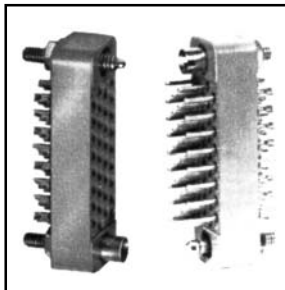

SRE
.030 Diameter Contacts — 5 Amps

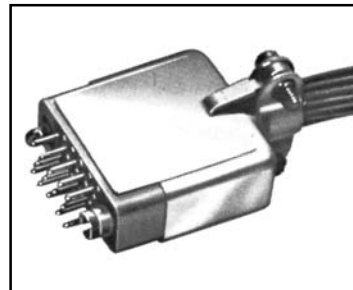

SME
.040 Diameter Contacts — 7.5 Amps

Within this series, you'll find a standard size connector for which you can select one of three current ratings: 3, 5 or 7.5 amps. Compact and lightweight, they are especially

suited for aircraft, instrumentation and portable equipment applications. Right angle, dip solder, pin or socket contacts are available. Consult factory.

SPECIFICATIONS

Current Rating: SLE - 3 amps; SRE - 5 amps; SME - 7.5 amps.

No. of Contacts: 4, 5, 7, 9, 11, 14, 20, 26, 29, 34, 44, 50.

Pin Contacts: Brass, gold plated except for SLE which is phosphor bronze, gold plated.

Socket Contacts: Phosphor bronze, gold plated.

Termination Types: .037 diameter solder cup will accept up to #22 AWG stranded wire. Solder cup adaptor (Part No. S45) will accept up to #20 AWG stranded wire. Dip solder terminations available for SRE Series, .030 Dia. Check Sales Department for available lengths.

Military versions of SRE are QPL'd to M28748/7 and M28748/8.

Electrical Data: The dielectric withstanding voltage is one minute

Dielectric: electrification at 1000 VAC. Green glass-filled diallyl phthalate per MIL-M-14, SDG-F.

Guides: Type NSS stainless steel, passivated or Type N Brass, gold plated.

Jackscrews: Stainless steel, passivated. Aluminum knobs on the jackscrews are equipped with set screws, except JTU jackscrews which have stainless steel knobs equipped with groove pins.

Hoods: Anodized aluminum. May be applied to either plug or receptacle. Both top and side openings are available for use with either guides or jackscrews.

Rack & Panel

SLE-SME-SRE Series

Sub Miniature / High Density Rectangular / .025" Dia. / 3 Amps
.030" Dia. / 5 Amps / .040" Dia. / 7.5 Amps

CONTACT ARRANGEMENT

Mating Face of Female Moldings - Male Moldings Reverse Image

Dimensions are for reference only and are subject to change. Outline drawings on request.

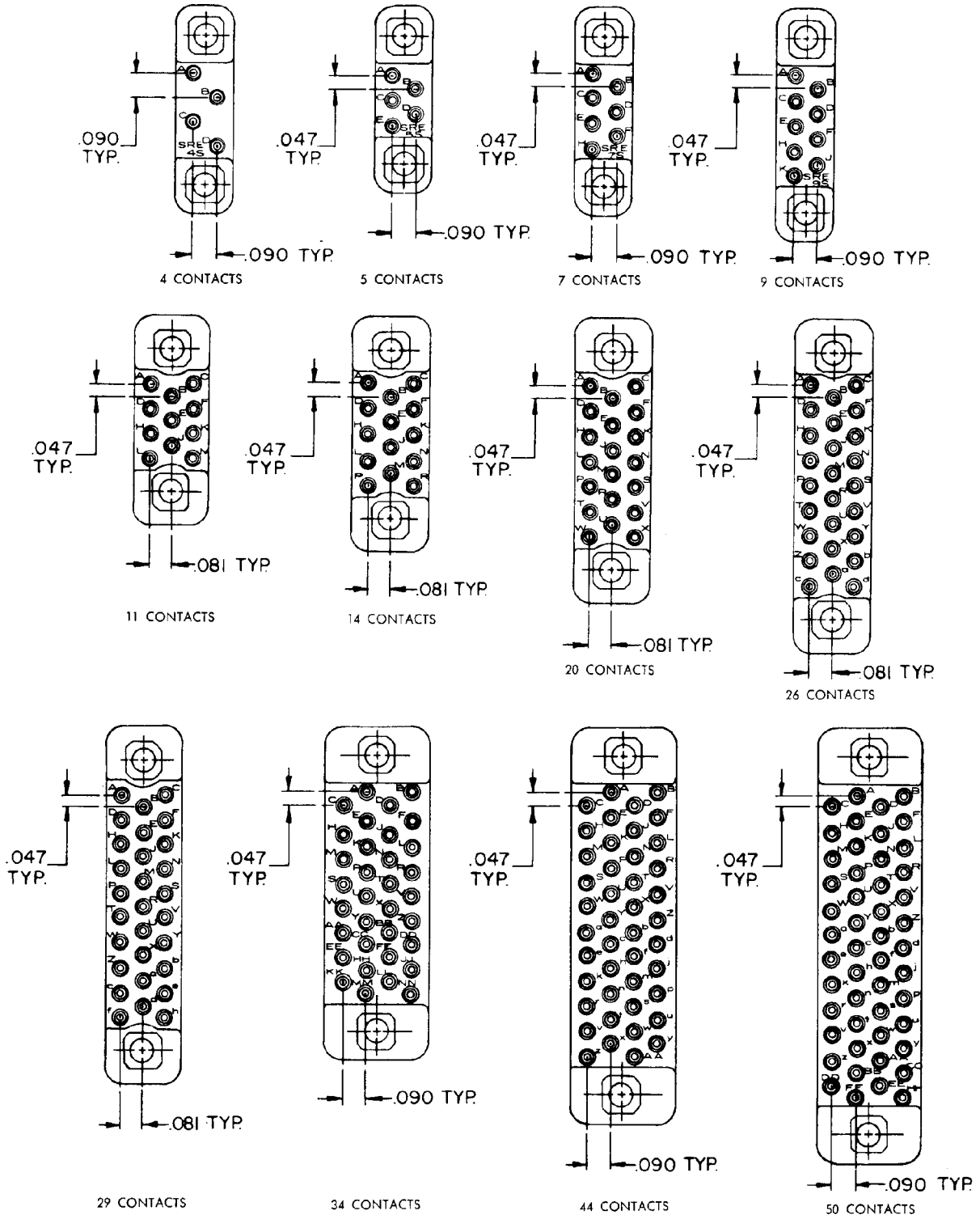

Winchester/Retconn

400 Park Road ■ Watertown, Connecticut 06795-0500 ■ Phone: (860) 945-5000 ■ FAX: (860) 945-5191 ■ Internet: <http://www.litton-wed.com>

Rack & Panel

SLE-SME-SRE Series

Sub Miniature / High Density Rectangular / .025" Dia. / 3 Amps
 .030" Dia. / 5 Amps / .040" Dia. / 7.5 Amps

OUTLINE

Dimensions are for reference only and are subject to change. Outline drawings on request.

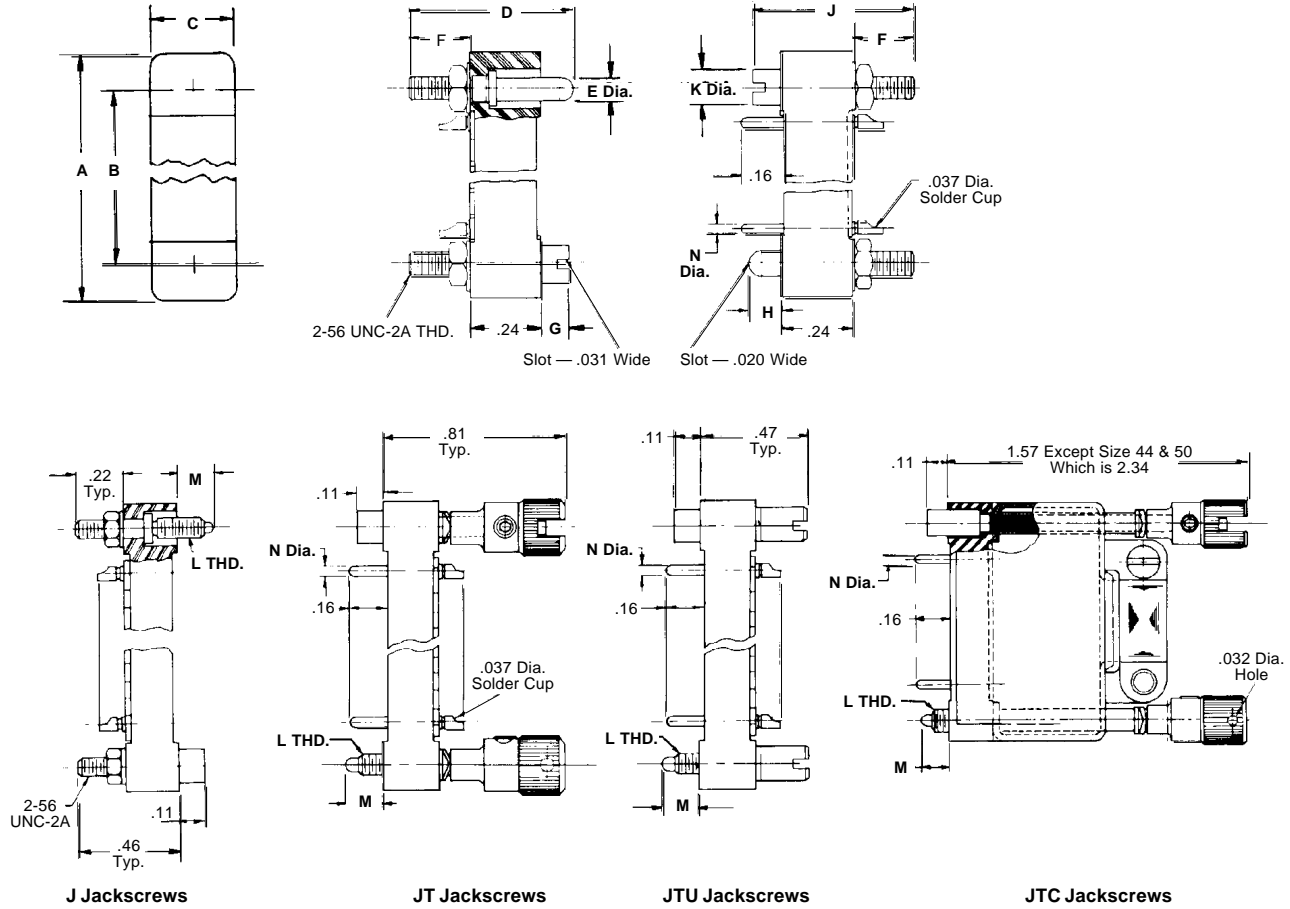

DIMENSIONS

The stainless steel guide pin and socket have good physical strength and are particularly desirable for mounting connectors which will be

subject to severe vibration in service, but not for electrical applications. Optional gold plated brass available for electrical applications.

No. of Contacts	A	B	C
4	.78	.562	.21
5	.70	.482	.21
7	.78	.562	.21
9	.88	.656	.21
11	.78	.531	.28
14	.88	.625	.28
20	1.06	.814	.28
26	1.25	1.000	.28
29	1.34	1.094	.28
34	1.25	1.032	.39
44	1.48	1.267	.39
50	1.63	1.408	.39

Series	D	E Dia	F	G	H	J	K	L Thd	M	N
SLE	.62	.08	.24	.10	.14	.59	.125	2-56 UNC	.15	.025
SRE	.57	.09	.22	.11	.12	.57	.137	3-48 UNC*	.12	.030
SME	.62	.08	.24	.10	.14	.59	.125	2-56 UNC	.15	.040

*2-56 UNC Thread also available.
 See ordering information for part number suffix.

Winchester/Retconn

400 Park Road ■ Watertown, Connecticut 06795-0500 ■ Phone: (860) 945-5000 ■ FAX: (860) 945-5191 ■ Internet: <http://www.litton-wed.com>

Rack & Panel

SLE-SME-SRE Series

**Sub Miniature / High Density Rectangular / .025" Dia. / 3 Amps
.030" Dia. / 5 Amps / .040" Dia. / 7.5 Amps**

OUTLINE

Hoods Formed Aluminum

Dimensions are for reference only and are subject to change. Outline drawings on request.

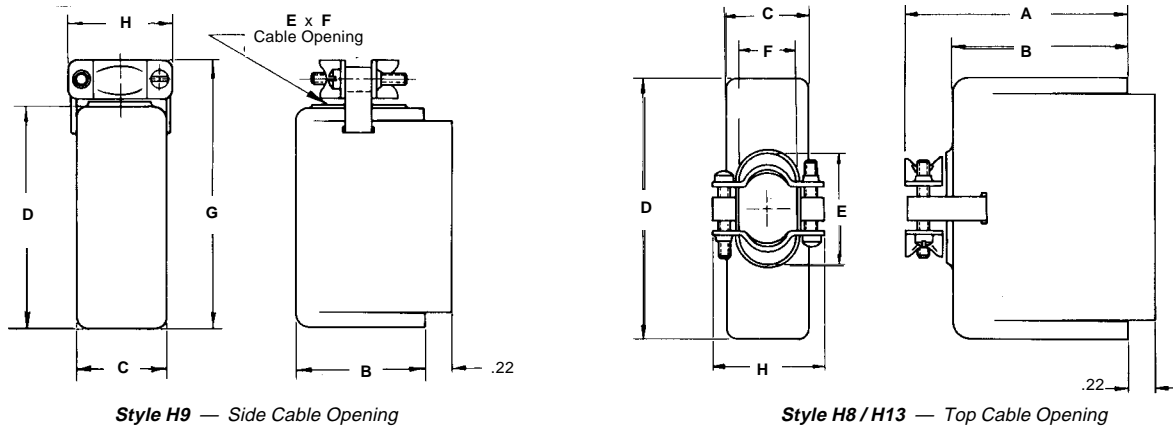

Style H9 — Side Cable Opening

Style H8 / H13 — Top Cable Opening

DIMENSIONS

Hood Style	Hood Catalog Number Guides Only*	Dimensions						Cable Opening		No. of Contacts
		A	B	C	D	G	H	E	F	
H8	SRE11H8	1.02	.72	.33	.78	—	.53	.28	.28	11
H8	SRE50H8	1.80	1.50	.45	1.63	—	.63	1.19	.38	50
H9	SRE11H9	—	.72	.33	.78	1.08	.53	.50	.22	11
H9	SRE50H9	—	1.50	.45	1.63	1.92	.63	1.19	.38	50
H13	SRE4&7H13	1.02	.75	.25	.78	—	.53	.22	.16	4 & 7
H13	SRE14H13	1.02	.75	.34	.88	—	.53	.25	.16	14
H13	SRE20H13	1.02	.75	.34	1.06	—	.53	.38	.25	20
H13	SRE26H13	1.02	.75	.34	1.25	—	.53	.41	.25	26
H13	SRE34H13	1.05	.75	.45	1.25	—	.63	.73	.38	34
NOT AVAILABLE										5
NOT AVAILABLE										9
H13	SRE29H13	1.02	.75	.34	1.34	—	.53	.41	.25	29
NOT AVAILABLE										44

* Add "J" to hood part number when used with fixed jackscrews
Add "JTC" to hood part number when used with long turning jackscrews.

ORDERING INFORMATION

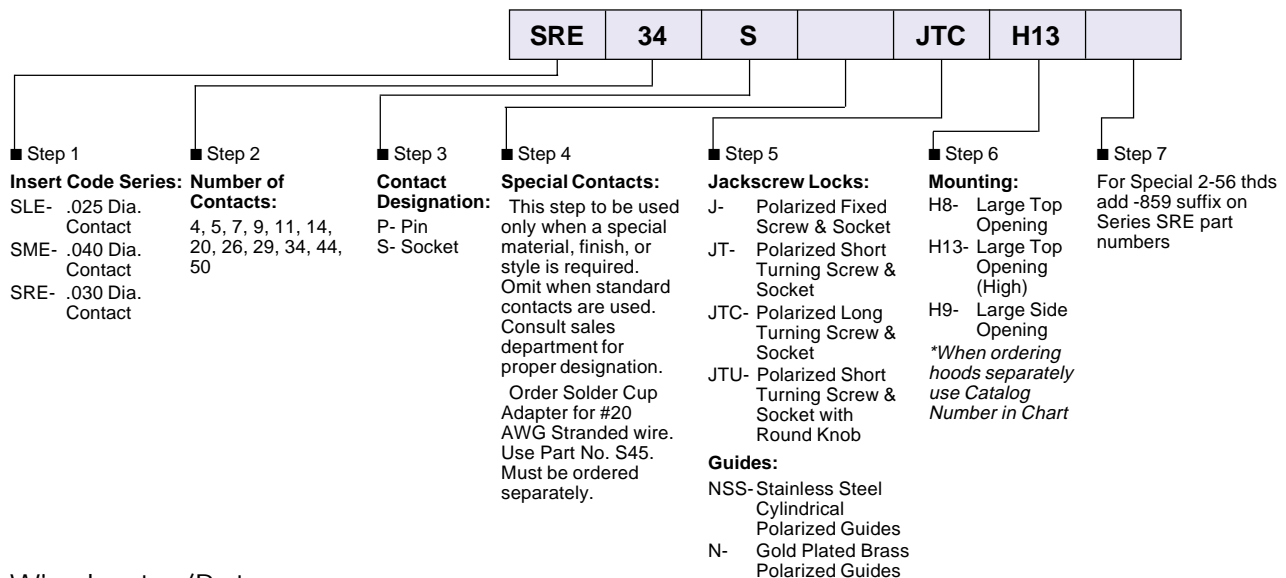

Winchester/Retconn

400 Park Road ■ Watertown, Connecticut 06795-0500 ■ Phone: (860) 945-5000 ■ FAX: (860) 945-5191 ■ Internet: <http://www.litton-wed.com>